

BLEEDING BRAKES WITH A BLEEDING UNIT

52: Replacing components



PRINT

Bleeding brakes with a bleeding unit

Note! Bleeding braking systems with ABS takes longer than bleeding conventional braking systems.

Guidelines for bleeding

When overhauling or replacing brake calipers, it is usually enough to bleed the brake pipe concerned as below. One condition is that the brake pedal must be depressed while working, so that the braking system is not drained of brake fluid. If the braking system has been drained, partly or completely, the complete braking system should be bled using the bleeding unit.

Note! Use only Volvo original brake fluid marked DOT 4+. Never re-use brake fluid. Always keep brake fluid in its original packing, well sealed.

Preparations

Ignition off.
Jack car up.
Clean filler cap on brake fluid reservoir and the surrounding area.

- Remove:
- Filler cap.

Set bleeding unit to 0.2-0.3 MPa (29-42.7 psi).

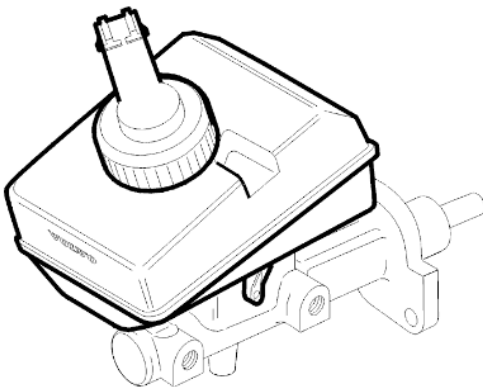

Connecting bleeding unit

- Connect bleeding unit to brake fluid reservoir.

Follow manufacturers' instructions for connecting and using bleeding unit.

- Depress brake pedal a few times to expel any air bubbles from the master cylinder.

Note! Repeat this step between bleeding each brake caliper.

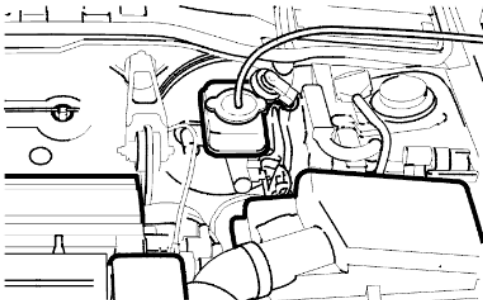

Bleeding LH front wheel

- Remove:
- Protective cap from bleed nipple and connect hose from drain bottle.

Open bleed nipple and close it again once no further air bubbles can be seen in the escaping fluid.
Tighten bleed nipple.

- Remove:
- Hose from bleed nipple and re-install protective cap.

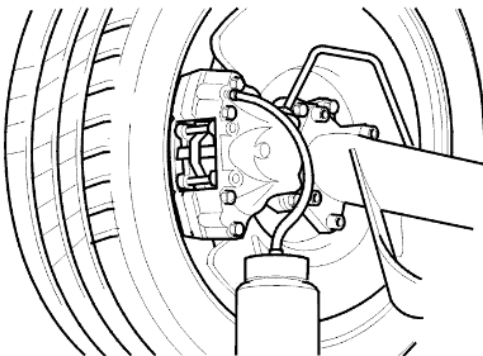

Bleeding other wheels

- Continue bleeding as per - in the following order:
- RH front wheel
 - LH rear wheel
 - RH rear wheel

- Remove:
- Bleeding unit connector from brake fluid reservoir.

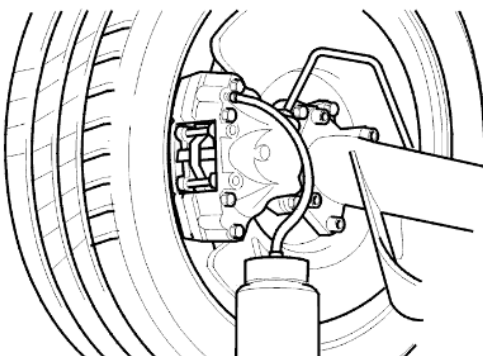

Check

- Check if there is any air left in the system by depressing the brake pedal as if braking sharply (a

Revision #1

Created 2025-06-22 12:19:19 UTC by Kyle Robertson

Updated 2025-06-22 12:20:03 UTC by Kyle Robertson